

Reliable solutions

ZW50

Tier 4 Final Certified

44 hp 32.8 kW
Engine Output, Max, Gross
(ISO 14396)

42 hp 31.8 kW
Engine Output, Max, Net
(ISO 9249)

0.8 yd³ 0.6 m³
Bucket capacity

9,350 lbs 4,240 kg
Operating weight

ZW80

Tier 4 Final Certified

66 hp 49 kW
Engine Output, Max, Gross
(ISO 14396)

63 hp 47 kW
Engine Output, Max, Net
(ISO 9249)

1.2 yd³ 0.9 m³
Bucket capacity

12,600 lbs 5,715 kg
Operating weight



NO COMPROMISE

Offering exceptional levels of performance without compromising on efficiency, Hitachi ZW-5b wheel loaders are designed to satisfy the requirements of the North American construction industry.

Designed to be reliable, durable and versatile for a variety of job sites, and to operate with low levels of fuel consumption, they incorporate the high-quality engineering for which Hitachi is renowned.



6. FIRST FOR RELIABILITY



8. DEDICATED TO COMFORT AND SAFETY



10. INCREDIBLE VERSATILITY



12. INDUSTRY-LEADING QUALITY



14. UNIQUE TECHNOLOGY

DEMAND PERFECTION

Designed and built with an emphasis on the environment, operator comfort and safety, the ZW-5b wheel loaders have been developed to perfection. They incorporate industry-leading technology created in Japan to meet the highest standards for performance at the lowest possible costs of ownership.



Improved fuel efficiency

Reliable Tier 4 Final compliant engines without DPF. Kubota (ZW50-5b), Deutz (ZW80-5b)





Innovative technology

HN Bushings impregnated with high viscosity oil extend lubrication period to 500 hours on linkage pins



Low running costs

Eco Mode provides a fuel efficient setting resulting in better fuel economy (ZW80-5b)



Convenient access

Easy access to cab on both sides of machine



Enhanced design

Wide-open engine hood and side-by-side aluminum radiator and aluminum oil cooler provide easy access for maintenance and cleaning



High versatility

Universal Coupler allows a wide range of attachments (ZW50-5b, standard) (ZW80-5b, optional)



Smooth operation

ZW50-5b Limited Slip Differentials and ZW80-5b Conventional with Front-Locking Differential provide additional traction for slippery surface conditions.



Enhanced durability

Wrap-around counterweight lowers center of gravity increasing stability

FIRST FOR RELIABILITY

Renowned for reliability, Hitachi ZW-5b wheel loaders achieve exceptional levels of performance and efficiency with minimum downtime. The ZW50-5b/ZW80-5b have been designed with several user-friendly features that ensure quick and easy maintenance, and also contribute to lower running costs.

Minimal downtime

The battery compartment can be accessed easily for maintenance and battery replacement. This results in minimal downtime and a high level of accessibility.

Quick access

Daily maintenance is simplified with the wide-open engine cover and low-profile counterweight. The engine cover can be opened at a touch and held with a gas damper for quick inspection, replacement, and replenishment.

Improved fuel efficiency

The ZW-5b demonstrates greater fuel efficiency than the previous model during V-shape loading and load and carry

operations. This results in considerable savings for running costs.

Easy maintenance

For safer and easier maintenance, the battery disconnect switch is now standard. This helps to avoid electrical accidents and retain battery energy during long-term storage. Battery electrolyte level can be checked at a glance through an opening in the counterweight (ZW80-5b).

Reduced cost

The new Tier 4 Final certified engine does not require a diesel particulate filter, which further reduces fuel consumption and maintenance costs.



Easy access to the engine compartment.





HITACHI



Easy to read monitor provides operating data at a glance (ZW50-5b)



The flat cab floor enables easy cleaning.



i The final pre-delivery inspection procedure for each Hitachi wheel loader is typical of Hitachi's dedication to manufacturing products of unflinching quality in response to customer needs.



DEDICATED TO COMFORT AND SAFETY

Industry-leading cab visibility, low noise level, and easily access to the walk-through type cab ensure the ZW50-5b and ZW80-5b are class leaders in operator comfort.



ZW80-5b

A standard long-stroke suspension seat absorbs shock and vibration (ZW80-5b).

Excellent Visibility

- Pillarless design offers unobstructed visibility.
- Front floor to ceiling windows.
- Cab enables panoramic views via addition of a lower window
- LED working lights (F/R) for better visibility.

Low Noise Level in Cab

The cab is sound insulated with integrating a highly sealed design. New low-noise engine, and rubber-mounted operator frame and hydraulics, contribute to reduced decibel levels.

Adjustable Suspension Seat

The suspension seat provided as standard equipment, absorbs shocks and vibration during operation, reducing operator fatigue and providing operator comfort.

ZW50-5b, short suspension seat, standard.

ZW80-5b, long suspension seat, standard.

Walkthrough Type Cab

The walkthrough type cab allows for easy access from either side. The flat floor enables easy cleaning.

INCREDIBLE VERSATILITY

ZW-5b wheel loaders are often described as a perfect fit by Hitachi customers, which illustrates their versatility for a wide range of applications and job sites. In addition, they are smooth and efficient to operate, and offer increased productivity and greater fuel efficiency.

Efficient flexibility

Switch attachments from the comfort of your cab with the Universal Quick Coupler, which enables the rapid and seamless replacement of working tools.

High efficiency

Manually locking front differentials are standard on the ZW80-5b. Limited Slip Differentials on the ZW50-5b provide added traction.

Superior performance

Rear axle oscillation provides a stable, comfortable ride for the operator, easily conforming to various terrains.





Universal Quick Couple allows seamless transition (ZW80-5b).



Rear visibility has been enhanced by design modifications.



The cab provides a quiet and comfortable working environment.



ZW80-5b

Easy access for maintenance from ground level.



i Hitachi conducts user tests in Japan to assess the features of its wheel loaders. Results have revealed an unrivaled level of control.

INDUSTRY-LEADING QUALITY

To set industry-leading standards in terms of performance, reliability, comfort and safety, the ZW50-5b/ZW80-5b have been built using components of the highest quality. Its clever design offers 360° visibility from the cab and ensures it is one of the quietest wheel loaders in its class.



ZW80-5b

The fuel cap and engine cover can be locked with the ignition key.

Reduced emission

Cutting-edge technology not only helps the environment, but also complies with Tier 4 Final emission regulations.

Easy access

Handrails and large steps mounted on both the left and right of the operator's station provide safety and easy access to the cab.

Excellent security

The control lever and auxiliary function levers lock for safety, while the fuel cap and engine cover can be locked with the engine key.

Improved comfort

Sound insulation has been improved in the cab to significantly reduce noise levels and provide a quieter working environment for operators. The low-noise engine also results in a quieter performance, which makes it suitable for working in urban areas.

UNIQUE TECHNOLOGY

Advanced technology developed by Hitachi is at the heart of the ZW-5b wheel loaders. It has an impact on everything, from the wheel loader's environmental performance to the comfort and safety of its operator. A technology-led approach enables Hitachi to meet the evolving needs of the construction industry, and improve the experience of its customers.

Reduced maintenance

A new Tier 4 Final certified engine contains a high-volume cooled exhaust gas recirculation (EGR) system, a common rail-type fuel injection system and a diesel oxidation catalyst (DOC). This helps to reduce fuel costs and maintenance requirements.

Smaller environmental impact

Eco Mode helps to prevent fuel waste and exhaust emissions without affecting productivity (ZW80-5b).

Optimum performance

The Throttle Limit Control reduces tire slippage, especially in wet and slippery conditions such as snow removal, dairy, and agriculture, saving on tire wear and tear (ZW80-5b).

Precise control

The inching/ brake pedal provides smooth deceleration and natural braking for precise operations at low speeds. The HST brake provides smooth startup on slopes and excellent traction at all speed ranges.

Smooth operation

The ZW50-5b, and ZW80-5b are easy to maneuver thanks to the HST control system. The operator can choose between two work modes according to the task and terrain, and it enables a smooth transition between speeds.



Easy-read monitor provides operating data at a glance



The HST control system enables a smooth performance.



The new engine has a smaller environmental impact.

REDUCING THE TOTAL COST OF OWNERSHIP

Hitachi has created the After Sales Solutions Program to ensure optimum efficiency, as well as minimal downtime, reduced running costs and high resale values.

Technical support

Each Hitachi service technician receives full technical training from HCMA in the USA. These sessions provide access to the same technical knowledge available within the Hitachi quality assurance departments and design centers. Technicians combine this global expertise with the local language and culture of the customer to provide the highest level of after-sales support.

Extended warranty and service contracts

Every new Hitachi ZW-5b model is covered by a full manufacturer's warranty. For extra protection — due to severe working conditions or to minimize equipment repair costs — Hitachi dealers offer a unique extended warranty called HELP (Hitachi Extended Life Program) and comprehensive service contracts. These can help to optimize the performance of each machine, reduce downtime and ensure higher resale values.

Parts

Hitachi offers a wide range, and high availability, of parts located in the new 400,000 sq. ft. Parts Depot centrally located just outside of Atlanta, Georgia.

- Hitachi Genuine Parts: allow machines to work longer, with lower running and maintenance costs.
- Hitachi Select Parts and Genuine Parts: are of proven quality and come with the manufacturer's warranty.
- Performance Parts: to cope with highly demanding conditions, they have been engineered for greater durability, better performance or longer life.

Whatever the choice, the renowned quality of Hitachi construction machinery is assured.



Technical support



Hitachi Parts



BUILDING A BETTER FUTURE

Established in 1910, Hitachi, Ltd. was built upon a founding philosophy of making a positive contribution to society through technology. This is still the inspiration behind the Hitachi group's reliable solutions that answer today's challenges and help to create a better world.

Hitachi, Ltd. is now one of the world's largest corporations, with a vast range of innovative products and services. These have been created to challenge convention, improve social infrastructure and contribute to a sustainable society.



Hitachi Construction Machinery Co., Ltd. (HCM) was founded in 1970 as a subsidiary of Hitachi, Ltd. and has become one of the world's largest construction equipment suppliers. A pioneer in producing hydraulic excavators, HCM also manufactures wheel loaders, rigid dump trucks, crawler cranes and special application machines at state-of-the-art facilities across the globe.

Incorporating advanced technology, Hitachi construction machinery has a reputation for the highest quality standards. Suitable for a wide range of industries, it is always

hard at work around the world – helping to create infrastructure for a safe and comfortable way of living, developing natural resources and supporting disaster relief efforts.

Hitachi ZW wheel loaders are renowned for being reliable, durable and versatile – capable of delivering the highest levels of productivity under the most challenging of conditions. They are designed to provide owners with a reduced total cost of ownership, and operators with the ultimate level of comfort and safety.

SPECIFICATIONS

ZW50-5b

Model Name: ZW50-5b, EPA Tier 4 Final/EU Stage IV Certified

ENGINE

Gross power (ISO 14396)	44 HP/2,400 RPM (32.8 kW/2,400 RPM)
Net power (ISO 9249)	42 HP/2,400 RPM (31.8 kW/2,400 RPM)
Make/Model	Kubota D1803-CR-TIE4 diesel engine
Type	4-cycle, water-cooled, direct injection with turbocharger and air cooled intercooler
Fuel type	#2 Diesel (Requires ultra-low sulfur fuel.)
Fuel injection pump	Electronically controlled, common rail type
Governor	All speed electrical type
Cooling module type	Forced circulation type
Number of cylinders	3
Bore and stroke	3.4" x 4.0" (87mm x 102.4mm)
Total displacement	112 in ³ (1.83 liters)
Alternator	DC 12V-70A (8.4 kW)
Air cleaner	Dry type (double element) with restriction indicator
Starter motor	DC 12V-2.7 HP (2.0 kW)
Battery	12V-800 CCA (70Ah), 2 units

TRANSMISSION

Transmission	Hydrostatic transmission (HST) automatically controls power and 2-speed	
	Normal Mode	
Speeds: Forward	Low:	5.0 MPH (8.0 km/hr)
	Auto:	10.6 MPH (17.0 km/hr)
Speeds: Reverse	Low:	5.0 MPH (8.0 km/hr)
	Auto:	10.6 MPH (17.0 km/hr)

SYSTEMS REFILL CAPACITY

LOCATION	GALLONS	LITERS
Fuel tank (diesel fuel)	11.1	42
Engine lubricant (including oil pan)	2.0	8
Engine coolant	1.7	7
T/M	0.5	2
Axle (front/rear)	1.2/1.2	5/5
Hydraulic oil tank	7.1	27

HYDRAULIC AND STEERING SYSTEM

Steering type	Articulated frame steering. Full hydraulic power steering unit, pilot operation	
Steering mechanism	Double-acting piston type	
Lift (boom) cylinder	Two (2) double-acting piston type: 2.8" x 20.9" (70mm x 531mm)	
Tilt (bucket) cylinder	Two (2) double-acting piston type: 2.8" x 17.7" (70mm x 450mm)	
Steering cylinder	Two (2) double-acting piston type: 2.4" x 9" (60mm x 228mm)	
Main oil pump	13.9 GPM/1,000 PSI @ 2,400 RPM (52.7 LPM/20.6 MPa @ 2,400 RPM)	
HST charging pump	4.0 GPM/3,260 PSI @ 2,400 RPM (15.3 LPM/2.5 MPa @ 2,400 RPM)	
Relief valve set pressure	Loading	2,987 psi, 20.6 MPa (210 kgf/cm ²)
HYDRAULIC CYCLE TIME* front end loading, Z bar linkage system		
Normal Mode		
Lifting time (at full load)	5.0 sec.	
Lowering time (empty)	3.0 sec.	
Bucket dumping time	1.0 sec.	
TOTAL	9.0 sec.	

* Measured in accordance with SAE J732C

AXLE SYSTEM

Drive system	4-wheel drive
Front and rear axle	Semi-floating type, fixed to the front frame, trunnion support
Tires	15.5/60-18 8PR (L-2)
Reduction and differential gear	Limited slip differential (LSD)
Final reduction gear	Inboard mounted, heavy duty planetary gear
Oscillation angle	Total 16 (+8, -8)°

BRAKE SYSTEM

Service brakes	Wet disc in reduction gear box
Parking/Emergency brake	Spring-applied, hydraulically-released wet disc

Remarks

- Materials and specifications are subject to change without notice and without any obligation on the part of the manufacturer.
- This information, while believed to be completely reliable, is not to be taken as warranty for which we assume legal responsibility.
- Dumping clearance and reach are measured from bucket edge in accordance with SAE J732C.
- Counterweight should not be used with tire ballast.
- This specification sheet may contain attachments and optional equipment not available in your area.

Please contact your local HCMA dealer for additional information.

BUCKET DATA

**Standard Arm with Quick Coupler
General Purpose w/ Bolt-on Cutting Edge**



			Canopy*	Cab
Capacity	Heaped	yd ³ (m ³)	0.8 (0.6)	0.8 (0.6)
	Struck	yd ³ (m ³)	0.7 (0.52)	0.7 (0.52)
A	Maximum dumping clearance	ft-in (mm)	7'10" (2,380)	7'10" (2,380)
B	Dumping reach (to front of bucket edge or tooth)	ft-in (mm)	3'3" (995)	3'3" (995)
C	Max. hinge pin height	ft-in (mm)	10'4" (3,140)	10'4" (3,140)
D	Digging depth (with bucket level)	in (mm)	2" (50)	2" (50)
Breakout force		lb (kN)	5,530 (24.6)	5,530 (24.6)
Bucket tilt-back angle	at ground level	degree	44°	44°
	E at carry position	degree	55°	55°
Overall	F Length	ft-in (mm)	16' (4,875)	16' (4,875)
	G Height (up to cab top)	ft-in (mm)	8'5" (2,565)	8'6" (2,595)
	H Height (bucket fully raised)	ft-in (mm)	13'6" (4,105)	13'6" (4,105)
	I Width (outside tire)	ft-in (mm)	5'5" (1,660)	5'5" (1,660)
	J Width (outside bucket)	ft-in (mm)	5'7" (1,690)	5'7" (1,690)
K	Tread	ft-in (mm)	4'2" (1,260)	4'2" (1,260)
L	Wheel base	ft-in (mm)	6'1" (1,850)	6'1" (1,850)
Clearance Circle (bucket carry position)	M at outside of bucket	ft-in (mm)	10'3" (3,125)	10'3" (3,125)
	at outside of tire	ft-in (mm)	12'8" (3,870)	12'8" (3,870)
N	Minimum ground clearance	in (mm)	12" (295)	12" (295)
O	Full articulation angle	degree	40°	40°
Operating weight (with ROPS cab)**		lb (kg)	8,810 (3,995)	9,350 (4,240)
Static tipping load***	Straight	lb (kg)	5,510 (2,500)	5,840 (2,650)
	Full turn	lb (kg)	4,480 (2,030)	4,760 (2,160)

Notes: * Canopy option available in US market only

** Includes ROPS/FOPS weight

*** Static tipping load and operating weight marked with** include 15.5/60-18 8PR (L-2) tires (no ballast) with lubricants, coolant, full fuel tank and operator.

All dimensions, weight and performance data based on ISO 6746-1:1987, ISO 7131:1997 and ISO 7546:1983

DIMENSIONS

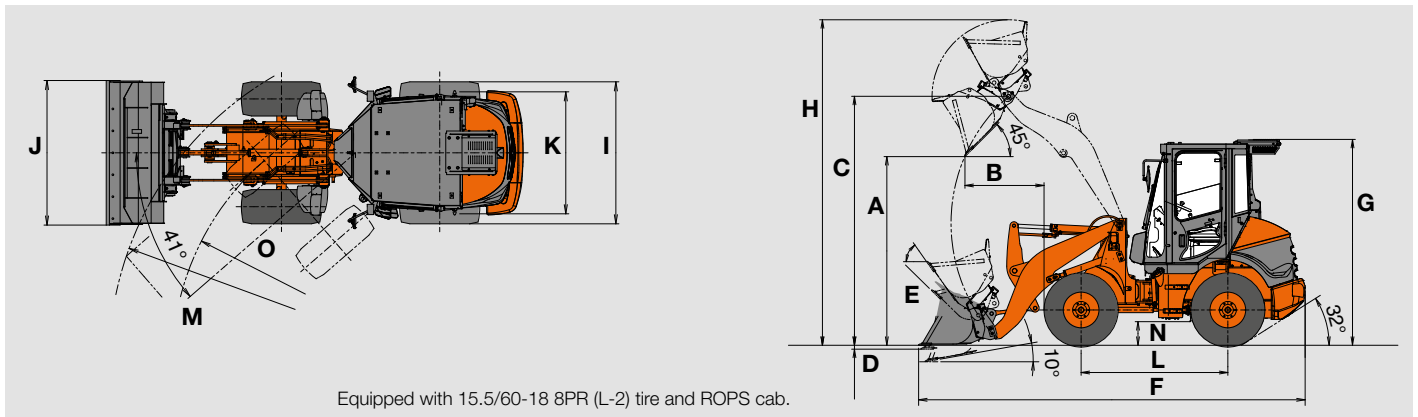

SPECIFICATIONS

ZW50-5b

ZW50-5b FORK SPECIFICATIONS

Fork type		Canopy*	Cab
A Fork tine length	ft (mm)	3'11" (1,195)	3'11" (1,195)
B Reach @ ground level	ft (mm)	3' (915)	3' (915)
C Maximum reach	ft (mm)	4'10" (1,475)	4'10" (1,475)
D Reach @ max hinge pin height	ft (mm)	2'6" (750)	2'6" (750)
E Fork height @ max reach	ft (mm)	4'10" (1,480)	4'10" (1,480)
F Fork height @ max hinge pin height	ft (mm)	10'2" (3,080)	10'2" (3,080)
Straight tip load with level arms and fork (load centered @ 24")	lb (kg)	4,040 (1,830)	4,260 (1,930)
Full turn tip load with level arms and fork (load centered @ 24")	lb (kg)	3,200 (1,450)	3,420 (1,550)
Max operating load (load centered @ 24")	lb (kg)	1,600 (725)	1,600 (725)
Fork attachment weight (load centered @ 24")	lb (kg)	360 (165)	360 (165)
Operating weight*** (load centered @ 24")	lb (kg)	8,860 (4,020)	9,370 (4,250)
G Overall length (load centered @ 24")	ft (mm)	17'11" (5,470)	17'11" (5,470)
H Overall height (load centered @ 24")	ft (mm)	8'5" (2,565)	8'5" (2,560)
I Fork width	ft (mm)	4' (1,225)	4' (1,225)
J Turning radius	ft (mm)	10'3" (3,125)	10'3" (3,125)
K Loader clearing radius, Fork in carry position	ft (mm)	13'2" (4,015)	13'2" (4,015)

Notes: * Canopy option available in US market only

** Static tipping load and operating weight marked with** include 15.5/60-18 8PR tires (no ballast) with lubricants, coolant, full fuel tank and operator.

*** Includes ROPS/FOPS weight

All dimensions, weight and performance data based on ISO 6746-1:1987, ISO 7131:1997 and ISO 7546:1983

DIMENSIONS

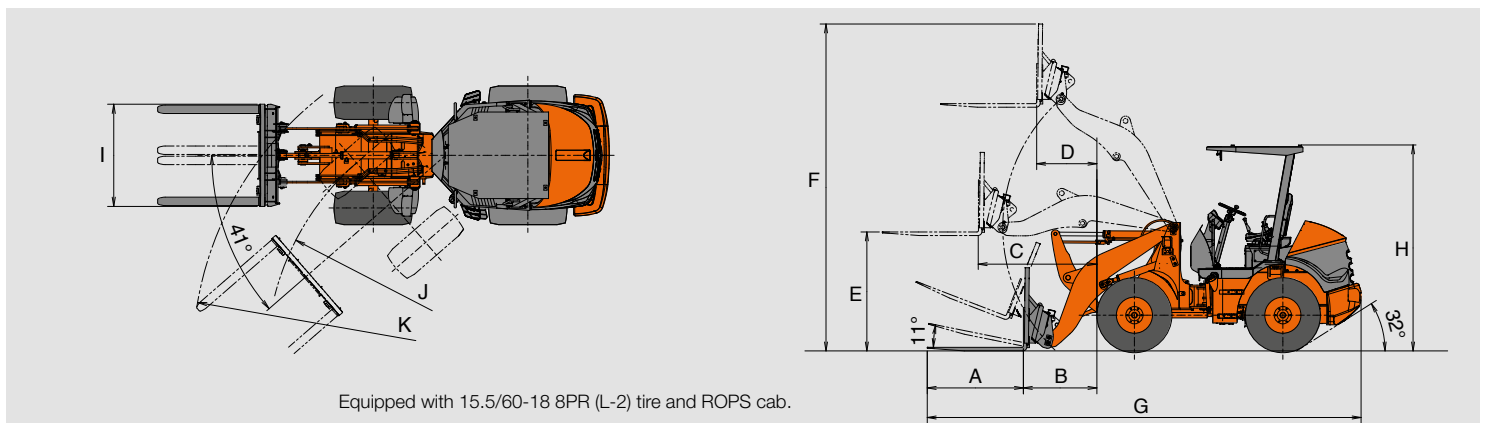

BUCKET SELECTION CHART

General purpose bucket with bolt-on cutting edges	Bucket capacity yd ³ (m ³)	Material density lb/yd ³ (kg/m ³)						% = Bucket Fill Factor		
		1,350 (800)	1,690 (1,000)	2,020 (1,200)	2,360 (1,400)	2,700 (1,600)	3,030 (1,800)	110%	100%	95%
Standard lift with quick-coupler	0.8 (0.6)									

STANDARD EQUIPMENT

ENGINE

Air filter double elements
 Air intake
 Cold start aid, glow plugs
 Engine oil filter, cartridge type
 Engine coolant reservoir
 Kubota D1803-CR-TIE4 diesel

POWERTRAIN

Brake, parking
 Enclosed wet disc type
 Spring applied
 Oil pressure released
 Brakes, service
 Enclosed wet disc type
 Full hydraulic system
 Electrically controlled HST system
 Forward/reverse lever
 Limited slip differential (LSD) for both axles
 Travel mode selector switch (L & Auto)

HYDRAULIC SYSTEM

Bucket auto leveler (automatic return to dig control)
 Coupler, hydraulic, universal type
 Hydraulic system, 3-function
 Control valve, 3-spool, parallel and tandem control
 Shift lever lock

ELECTRICAL

Alternator, DC 12V-70A (8.4 kW)
 Battery, 12V-800 CCA (70Ah)
 Battery disconnect cable
 Horn, electric
 Lights:
 2 Headlights (halogen)
 2 Stop/tail/turn lights (halogen)
 2 Turn signals (front) (halogen)
 1 Backup (halogen)
 Working lights (LED for Cab only) 2 front, 2 rear

CAB

AM/FM/WB Stereo Radio with AUX input
 Coat hook
 Cup holder
 Floor mat, sweep-out
 ROPS/FOPS Cab, ISO 3449 Level II compliant (Canada)*
 ROPS/FOPS Canopy (US)
 Seat, adjustable suspension, fabric (cab only)
 Seat, adjustable suspension, vinyl (canopy only)
 Seat belt, adjustable (3 inch)

* Canopy option available in US market only.

OTHERS

Articulation locking bar
 Counterweight
 Drawbar
 Fenders
 Linkage (Z-type, sealed w/HN bushings)
 Neutral safety start
 Rear grill, hinged
 Radiator, dust screen
 Radiator, side-by-side w/oil cooler

ALARMS, GAUGES, INDICATORS

Alarms (audible)	Brake oil level
	Engine coolant temp
	Engine oil pressure
Alarms (visual)	Air filter
	Battery discharge
	Brake oil level
	Engine oil pressure
	Engine coolant temperature
Gauges	Machine service
	Engine coolant temperature
	Engine tachometer
Indicators	Fuel gauge
	Clearance light
	Cold start
	Forward/reverse
	Hour meter
	High beam
	Parking brake
	Turn signal w/4-way flashers
	Travel mode (L)
	Working light, indicator (cab only)

SPECIFICATIONS

ZW80-5b

Model Name: ZW80-5b, EPA Tier 4 Final/EU Stage IV Certified

ENGINE

Gross power (ISO 14396)	66 HP/2,200 RPM (49 kW/2,200 RPM)
Net power (ISO 9249)	63 HP/2,200 RPM (47 kW/2,200 RPM)
Make/Model	Deutz TD2.9L4 diesel engine
Type	4-cycle, water-cooled, direct injection with turbocharger and air cooled intercooler
Fuel type	#2 Diesel (Requires ultra-low sulfur fuel.)
Fuel injection pump	Electronically controlled, common rail type
Governor	All speed electrical type
Cooling module type	Forced circulation type
Number of cylinders	4
Bore and stroke	3.6" x 4.3" (92mm x 110mm)
Total displacement	179 in ³ (2.93 liters)
Alternator	AC 14V-95A (13.3 kW)
Air cleaner	Dry type (double element) with restriction indicator
Starter motor	DC 12V-4.4 HP (3.2 kW)
Battery	12V-800 CCA (92 Ah), 2 units

TRANSMISSION

Transmission	Hydrostatic transmission (HST) automatically controls power and 2-speed	
	Normal Mode	
Speeds: Forward	1st:	7.5 MPH (12.0 km/hr)
	2nd:	21.1 MPH (34.0 km/hr)
Speeds: Reverse	1st:	7.5 MPH (12.0 km/hr)
	2nd:	21.1 MPH (34.0 km/hr)

SYSTEMS REFILL CAPACITY

LOCATION	GALLONS	LITERS
Fuel tank (diesel fuel)	21.7	82
Engine lubricant (including oil pan)	2.4	9
Engine coolant	4	15
T/M	0.2	1
Axle (front/rear)	1.6/1.7	6.2/6.4
Hydraulic oil tank	19	72

HYDRAULIC AND STEERING SYSTEM

Steering type	Articulated frame steering	
Steering mechanism	Double-acting piston type	
Lift (boom) cylinder	Two (2) double-acting piston type: 3.2" x 21.7" (85mm x 552mm)	
Tilt (bucket) cylinder	Two (2) double-acting piston type: 3.1" x 18.0" (80mm x 457mm)	
Steering cylinder	Two (2) double-acting piston type: 1.8" x 13.4" (45mm x 340mm)	
Main oil pump	20.1 GPM/1,000 PSI @ 2,200 RPM (76 LPM/20.6 MPa @ 2,200 RPM)	
HST charging pump	10.8 GPM/3,260 PSI @ 2,200 RPM (41 LPM/2.5 MPa @ 2,200 RPM)	
Relief valve set pressure	Loading	2,987 psi, 20.6 MPa (210 kgf/cm ²)
HYDRAULIC CYCLE TIME* front end loading, Z bar linkage system		
Normal Mode		
Lifting time (at full load)	5.0 sec.	
Lowering time (empty)	3.5 sec.	
Bucket dumping time	1.0 sec.	
TOTAL	9.5 sec.	

* Measured in accordance with SAE J732C

AXLE SYSTEM

Drive system	4-wheel drive
Front and rear axle	Semi-floating type, fixed to the front frame, center pivot
Tires	17.5-65-20 10PR (L-2)
Reduction and differential gear	Differential lock (front axle only)
Final reduction gear	Inboard mounted, heavy duty planetary gear
Oscillation angle	Total 22 (+11, -11)°

BRAKE SYSTEM

Service brakes	Inboard mounted fully hydraulic wet disc brakes
Parking/Emergency brake	Spring-applied, hydraulically-released wet disc

Remarks

- Materials and specifications are subject to change without notice and without any obligation on the part of the manufacturer.
- This information, while believed to be completely reliable, is not to be taken as warranty for which we assume legal responsibility.
- Dumping clearance and reach are measured from bucket edge in accordance with SAE J732C.
- Counterweight should not be used with tire ballast.
- This specification sheet may contain attachments and optional equipment not available in your area.

Please contact your local HCMA dealer for additional information.

BUCKET DATA

**Standard Arm with Quick Coupler
General Purpose w/ Bolt-on Cutting Edge**



			Canopy*	Cab
Capacity	Heaped	yd ³ (m ³)	1.2 (0.9)	1.2 (0.9)
	Struck	yd ³ (m ³)	1.0 (0.73)	1.0 (0.73)
A	Maximum dumping clearance	ft-in (mm)	7'10" (2,390)	7'10" (2,390)
B	Dumping reach (to front of bucket edge or tooth)	ft-in (mm)	3'3" (990)	3'3" (990)
C	Max. hinge pin height	ft-in (mm)	10'5" (3,165)	10'5" (3,165)
D	Digging depth (with bucket level)	in (mm)	3" (65)	3" (65)
Breakout force		lb (kN)	8,270 (36.8)	8,270 (36.8)
Bucket tilt-back angle	at ground level	degree	41°	41°
	E at carry position	degree	49°	49°
Overall	F Length	ft-in (mm)	17'8" (5,395)	17'8" (5,395)
	G Height (up to cab top)	ft-in (mm)	9'5" (2,860)	9'6" (2,890)
	H Height (bucket fully raised)	ft-in (mm)	13'8" (4,170)	13'8" (4,170)
	I Width (outside tire)	ft-in (mm)	6'4" (1,920)	6'4" (1,920)
	J Width (outside bucket)	ft-in (mm)	6'5" (1,956)	6'5" (1,956)
K	Tread	ft-in (mm)	4'10" (1,470)	4'10" (1,470)
L	Wheel base	ft-in (mm)	7'3" (2,200)	7'3" (2,200)
Clearance Circle (bucket carry position)	M at outside of bucket	ft-in (mm)	12'5" (3,795)	12'5" (3,795)
	at outside of tire	ft-in (mm)	14'11" (4,540)	14'11" (4,540)
N	Minimum ground clearance	in (mm)	13" (340)	13" (340)
O	Full articulation angle	degree	40°	40°
Operating weight (with ROPS cab)**		lb (kg)	12,100 (5,500)	12,600 (5,715)
Static tipping load***	Straight	lb (kg)	8,030 (3,640)	8,470 (3,840)
	Full turn	lb (kg)	6,790 (3,080)	7,170 (3,250)

Notes: * Canopy option available in US market only

** Includes ROPS/FOPS weight

*** Static tipping load and operating weight marked with*** include 17.5/65-20 10PR tires (no ballast) with lubricants, coolant, full fuel tank and operator.

All dimensions, weight and performance data based on ISO 6746-1:1987, ISO 7131:1997 and ISO 7546:1983

DIMENSIONS

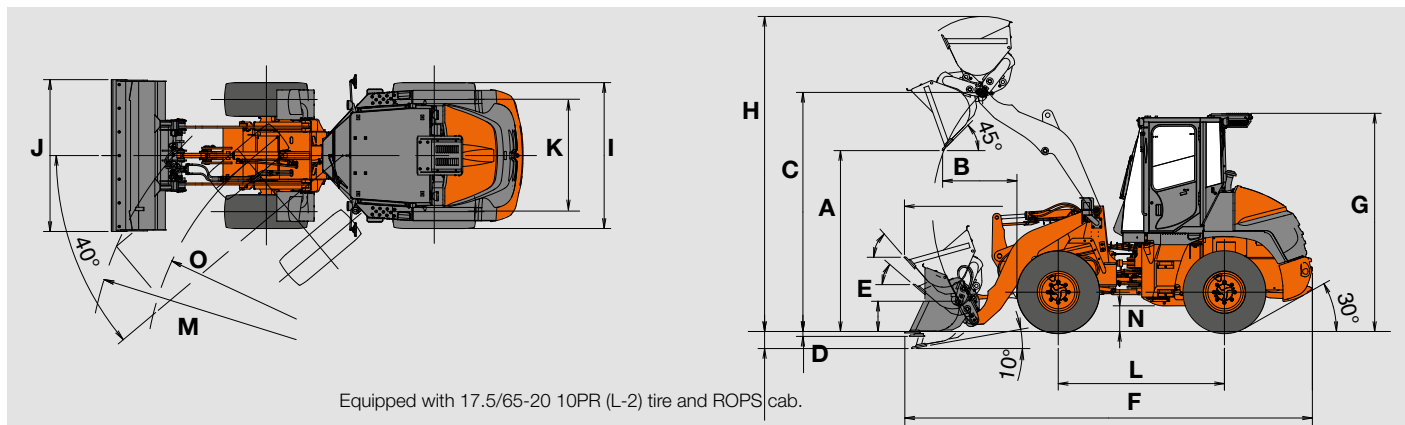

SPECIFICATIONS

ZW80-5b

ZW80-5b FORK SPECIFICATIONS

Fork type		Canopy*	Cab
A Fork tine length	ft (mm)	4' (1,220)	4' (1,220)
B Reach @ ground level	ft (mm)	2'7" (780)	2'7" (780)
C Maximum reach	ft (mm)	4'5" (1,335)	4'5" (1,335)
D Reach @ max hinge pin height	ft (mm)	2'3" (680)	2'3" (680)
E Fork height @ max reach	ft (mm)	4'11" (1,505)	4'11" (1,505)
F Fork height @ max hinge pin height	ft (mm)	10'1" (3,060)	10'1" (3,060)
Straight tip load with level arms and fork (load centered @ 24")	lb (kg)	5,950 (2,700)	6,310 (2,860)
Full turn tip load with level arms and fork (load centered @ 24")	lb (kg)	5,005 (2,270)	5,335 (2,420)
Max operating load	lb (kg)	3,175 (1,440)	3,175 (1,440)
Fork attachment weight	lb (kg)	683 (311)	683 (311)
Operating weight***	lb (kg)	12,125 (5,500)	12,599 (5,715)
G Overall length	ft (mm)	19'5" (5,915)	19'5" (5,915)
H Overall height	ft (mm)	9'5" (2,860)	9'6" (2,890)
I Fork width	ft (mm)	6'4" (1,920)	6'4" (1,920)
J Turning radius	ft (mm)	14'7" (4,440)	14'7" (4,440)
K Loader clearing radius, Fork in carry position	ft (mm)	15' (4,570)	15' (4,570)

Notes: * Canopy option available in US market only

** Static tipping load and operating weight marked with** include 17.5/65-20 10PR tires (no ballast) with lubricants, coolant, full fuel tank and operator.

*** Includes ROPS/FOPS weight

All dimensions, weight and performance data based on ISO 6746-1:1987, ISO 7131:1997 and ISO 7546:1983

DIMENSIONS

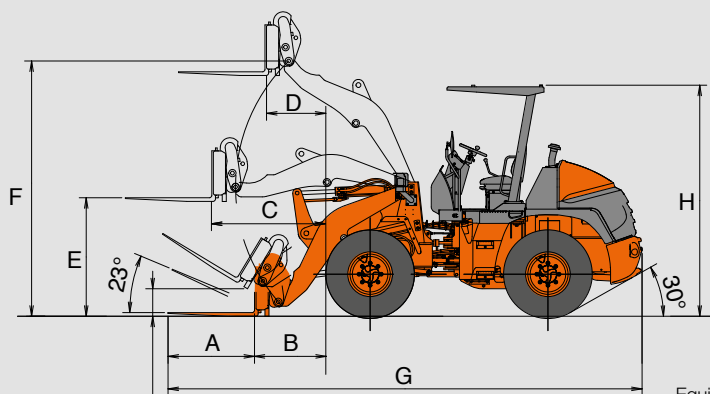

Equipped with 17.5/65-20 10PR (L-2) tire and ROPS cab.

BUCKET SELECTION CHART

%=Bucket Fill Factor 110% 100% 95%

General purpose bucket with bolt-on cutting edges	Bucket capacity yd ³ (m ³)	Material density lb/yd ³ (kg/m ³)							
		1,350 (800)	1,690 (1,000)	2,020 (1,200)	2,360 (1,400)	2,700 (1,600)	3,030 (1,800)		
Standard lift with quick-coupler	1.2 (0.9)								

STANDARD EQUIPMENT

ENGINE

Cold start aid, glow plugs
 DEUTZ TDZ2.9L4 diesel
 Engine coolant reservoir
 Fuel pre-filter w/water separator
 Throttle limit switch

POWERTRAIN

Brake, parking
 Enclosed wet disc type
 Spring applied
 Oil pressure released

Brakes, service

Enclosed wet disc type
 Full hydraulic system
 Differential lock (front axle only), grip-switch activated
 Inching pedal function

HYDRAULIC SYSTEM

Bucket positioner
 Coupler, hydraulic hook type*
 Hydraulic system, 3-function
 Control valve, 3-spool, parallel and tandem control
 Shift lever lock
 Travel mode switch

* Available in US market only.

ELECTRICAL

Alternator, AC 14V-95A (13.3 kW)
 Battery, 12V-680 CCA (92 Ah)
 Battery disconnect switch
 Horn, electric
 Lights:
 2 Headlights (halogen)
 2 Stop/tail/turn lights (halogen)
 2 Turn signals (front) (halogen)
 1 Backup (halogen)
 Working lights (Halogen for Cab only) 2 front, 2 rear

CAB

AM/FM/WB Stereo Radio with AUX input
 Floor mat, sweep-out
 ROPS/FOPS Cab, ISO 3449 Level II compliant (Canada)*
 ROPS/FOPS Canopy (US)
 Seat, adjustable suspension, fabric (cab only)
 Seat, adjustable suspension, vinyl (canopy only)
 Seat belt, adjustable (3 inch)
 * Canopy option available in US market only.

OTHERS

Articulation locking bar
 Coat hook
 Counterweight
 Cup holder
 Drawbar
 Fenders
 Linkage (Z-type, sealed w/HN bushings)
 Neutral safety start
 Rear grill, hinged
 Radiator, dust screen
 Radiator, side-by-side w/oil cooler
 Ride control

ALARMS, GAUGES, INDICATORS

Alarms (audible)	Brake oil level	
	Engine coolant temp	
	Engine oil pressure	
Alarms (visual)	Air filter	
	Battery discharge	
	Brake oil level	
	Engine coolant temperature	
	Engine oil pressure	
	HST warning	
	Machine service	
	Machine stop	
	Gauges	Engine coolant temperature
		Fuel gauge
Indicators	Clearance light	
	Cold start	
	Forward/reverse	
	Hour meter	
	High beam	
	Parking brake	
	Speedometer	
	Turn signal w/4-way flashers	
Working light, indicator (cab only)		

OPTIONAL EQUIPMENT

Coupler, hydraulic, universal



HITACHI

Reliable solutions



REPUTATIONS ARE
BUILT ON IT.

With manufacturing facilities in Banshu, Ryugasaki, Tierra, Hitachinaka, and Tsuchiura, Japan, and the U.S. corporate office and campus in Newnan, Georgia, Hitachi Construction Machinery Americas Inc. (HCMA) has the experience and technology to design, engineer, manufacture, and service your Hitachi construction machinery. The HCMA team is securely poised as your go-to source in the North American and Latin American construction machinery market.

Through our long-term commitment to maintaining a leadership position in technology, service, and support, HCMA supports an extensive network of independent, local dealers focused on providing you with knowledgeable and experienced sales, service, and parts personnel. All backed by dedicated HCMA support teams.

Your HCMA dealer has the resources, expertise and personnel to work with you to ensure that you receive the most benefit from your Hitachi investment utilizing carefully designed programs and services in conjunction with extensive digital resources. HCMA provides a totally focused approach to supporting you, your business, and your Hitachi construction machinery.

Machines representative of global product. Options may not be available in all markets. Prior to operating this machine, including satellite communication system, in a country other than a country of its intended use, it may be necessary to make modifications to it so that it complies with the local regulatory standards (including safety standards) and legal requirements of that particular country. Please do not export or operate this machine outside the country of its intended use until such compliance has been confirmed. Please contact your Hitachi dealer in case of questions about compliance.